



**PELICAN
Whole House
Water Filter System.**

01.

What is the Pelican Water filtration System?

The Pelican Carbon Series Whole House Water Filter System is a low-maintenance, easy to install system. It is the ultimate whole house water filtration system - no other system addresses as many chemicals.

According to Yales Water Quality Index, Egypt ranks as number 119th worldwide. The water in Egypt contains industrial and agricultural waste residue as well as high amounts of purification byproducts such as chlorine and chloramine to control bacteria and viruses. Hence, it is crucial to own a water purification system at home to protect your

family from harmful contaminants and enjoy fresh, purified water right from your faucet and shower.

The Pelican Whole House Water Filter is a high-capacity filtration system and can be easily installed in any home indoor or outdoor.

Pelican's Whole House Water Filter has the ability to purify 600,000 to 1,000,000 gallons and can last 3-4 years before the carbon media needs to be replaced.



WHY Choose Pelican Water:

The Pelican Whole House Water Filter is one of the best Whole House Water filters in terms of performance, quality and price. It is able to purify your water from: Chlorine and chloramines, Pesticides, Herbicides, Pharmaceuticals, industrial solvents and hundreds of other contaminants. The Filtration process creates zero waste water and does not require electricity.



1) Removes silt & sediment



6) Softer skin and hair



11) Low maintenance



2) Removes 97% Chlorine up to 1.301mil Gallons



7) Keeps beneficial minerals in the water



12) Protects plumbing and appliances from sediment



3) Reduces VOC's, Pharmaceuticals, industrial solvents & more



8) No water waste



13) 2 Years Tank warranty/ 1 year parts warranty



4) Certified performance by NSF/ANSI - USA



9) No electricity needed



5) Improves taste and smell of the water



10) Easy installation (indoor/outdoor)



Stages:



Stage 1

5-Micron Pre-filter System: The sediment pre-filter system reduces sand, silt, sediment and debris in the supplied water down to 5 micron (20 times smaller than a human hair) in size. This cost-effective Pre-filter requires replacement with average use every 3-4 month.



Stages 2 & 3

Catalytic Granular Activated Carbon Media (GAC): Pelican utilizes a high-grade mesh blend of catalytic coconut shell based activated carbon. These media are designed to filter chlorine, chloramines, pesticides, herbicides, pharmaceuticals, industrial solvents and hundreds of other contaminants that may be present in your water.

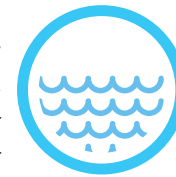

Stage 4

Pelican Media Guard: This is a patented bacteriostatic copper-zinc reduction oxidation media for the purpose of preventing and reducing the potential growth of bacteria and algae.

As a market leader, Pelican Water uses only the top-rated valves and tanks in the manufacturing of each Pelican system, all of which are backed by an industry leading limited lifetime parts warranty.



04. Specs & Product Informa- tion:

PC600

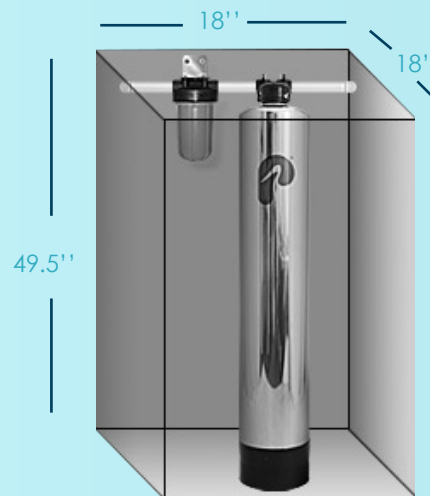

SYSTEM DIMENSIONS: PC600

Tank Width:	9"
Flow Rate:	8 GPM Service/ 12 GPM Peak
Connection Size:	1"
Operating Pressure:	25-80 PSI
Operating Temperatures:	38-120 F
FILTER MEDIA CHANGE:	
Sediment Prefilter:	Every 6-9 months
Tank 1 Media (PC600):	Every 3-4 years or 650,885 Gal

PC1000

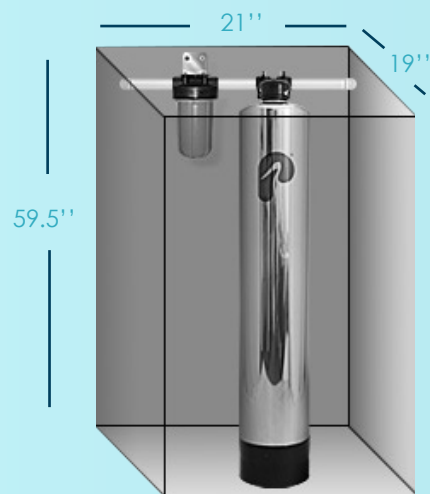

SYSTEM DIMENSIONS: PC1000

Tank Width:	11"
Flow Rate:	12 GPM Service/ 16 GPM Peak
Connection Size:	1"
Operating Pressure:	25-80 PSI
Operating Temperatures:	38-120 F
FILTER MEDIA CHANGE:	
Sediment Prefilter:	Every 6-9 months
Tank 1 Media (PC1000)	Every 3-4 years or 1,301,770 Gal

05.

Difference between: Water Softener , Reverse Osmosis & Pelican whole house water filter

A Water softener eliminates calcium and magnesium from the water to make the water softer. It does not address other chemicals that can be harmful to the human body. The aim of the water softener is solely to make water softer by adding salts to the water.

A Reverse Osmosis system is a filter system that removes a wide range of contaminants from the water but also beneficial minerals. Reverse osmosis systems are used as a point-of-use filter under the sink and cannot purify the water for the whole house. They create high amounts of waste water.

Pelican's Whole House Water Filter is the only filter that can purify the water for your entire house and makes it safe for the human body. It removes harmful contaminants from your water but keeps the beneficial minerals your body needs. It is economical as it creates zero waste water and helps to maintain your appliances by protecting them from pollutants. It is your ultimate solution when you want to enjoy the benefits of purified water from your shower, faucets and kitchen.



www.PelicanEgypt.com



AA Engineering Trading Co.
Office Building #259
Road 90 North, 5th Settlement
New Cairo



(+202) 24177443
(+202) 24183010
(+2) 01022639027



www.PelicanEgypt.com



info@adel-amin.com



Made in USA